

## Intended use

Your Black & Decker Compact Chainsaw has been designed for light duty cutting and pruning. This tool is intended for consumer use only.

## Safety instructions

### General power tool safety warnings



**Warning! Read all safety warnings and all instructions.** Failure to follow all instructions may result in electric shock, fire and/or serious injury.

### Save all warnings and instructions for future reference.

The term "power tool" in all of the warnings listed below refers to your mains operated (corded) power tool or battery operated (cordless) power tool.

1. **Work area safety**
  - a. **Keep work area clean and well lit.** Cluttered and dark areas invite accidents.
  - b. **Do not operate power tools in explosive atmospheres, such as in the presence of flammable liquids, gases or dust.** Power tools create sparks which may ignite the dust or fumes.
  - c. **Keep children and bystanders away while operating a power tool.** Distractions can cause you to lose control.
2. **Electrical safety**
  - a. **Power tool plugs must match the outlet. Never modify the plug in any way. Do not use any adapter plugs with earthed (grounded) power tools.** Unmodified plugs and matching outlets will reduce risk of electric shock.
  - b. **Avoid body contact with earthed or grounded surfaces such as pipes, radiators, ranges and refrigerators.** There is an increased risk of electric shock if your body is earthed or grounded.
  - c. **Do not expose power tools to rain or wet conditions.** Water entering a power tool will increase the risk of electric shock.
  - d. **Do not abuse the cord. Never use the cord for carrying, pulling or unplugging the power tool. Keep cord away from heat, oil, sharp edges or moving parts.** Damaged or entangled cords increase the risk of electric shock.
  - e. **When operating a power tool outdoors, use an extension cord suitable for outdoor use.** Use of a cord suitable for outdoor use reduces the risk of electric shock.
  - f. **If operating a power tool in a damp location is unavoidable, use a Residual Current Device (RCD) protected supply.** Use of an RCD reduces the risk of electric shock.
3. **Personal safety**
  - a. **Stay alert, watch what you are doing and use common sense when operating a power tool. Do not use a power tool while you are tired or under the influence of drugs, alcohol or medication.** A moment of inattention while operating power tools may result in serious personal injury.
  - b. **Use personal protective equipment. Always wear eye protection.** Protective equipment such as dust mask, non-skid safety shoes, hard hat, or hearing protection used for appropriate conditions will reduce personal injuries.
  - c. **Prevent unintentional starting. Ensure the switch is in the off-position before connecting to power source and/or battery pack, picking up or carrying the tool.** Carrying power tools with your finger on the switch or energising power tools that have the switch on invites accidents.
  - d. **Remove any adjusting key or wrench before turning the power tool on.** A wrench or a key left attached to a rotating part of the power tool may result in personal injury.
  - e. **Do not overreach. Keep proper footing and balance at all times.** This enables better control of the power tool in unexpected situations.
  - f. **Dress properly. Do not wear loose clothing or jewellery. Keep your hair, clothing and gloves away from moving parts.** Loose clothes, jewellery or long hair can be caught in moving parts.
  - g. **If devices are provided for the connection of dust extraction and collection facilities, ensure these are connected and properly used.** Use of these devices can reduce dust related hazards.
4. **Power tool use and care**
  - a. **Do not force the power tool. Use the correct power tool for your application.** The correct power tool will do the job better and safer at the rate for which it was designed.
  - b. **Do not use the power tool if the switch does not turn it on and off.** Any power tool that cannot be controlled with the switch is dangerous and must be repaired.
  - c. **Disconnect the plug from the power source and/or the battery pack from the power tool before making any adjustments, changing accessories, or storing power tools.** Such preventive safety measures reduce the risk of starting the power tool accidentally.

d. **Store idle power tools out of the reach of children and do not allow persons unfamiliar with the power tool or these instructions to operate the power tool.**

Power tools are dangerous in the hands of untrained users.

e. **Maintain power tools. Check for misalignment or binding of moving parts, breakage of parts and any other condition that may affect the power tools operation. If damaged, have the power tool repaired before use.** Many accidents are caused by poorly maintained power tools.

f. **Keep cutting tools sharp and clean.** Properly maintained cutting tools with sharp cutting edges are less likely to bind and are easier to control.

g. **Use the power tool, accessories and tool bits etc. in accordance with these instructions, taking into account the working conditions and the work to be performed.** Use of the power tool for operations different from those intended could result in a hazardous situation.

#### 5. Battery tool use and care

a. **Recharge only with the charger specified by the manufacturer.** A charger that is suitable for one type of battery pack may create a risk of fire when used with another battery pack.

b. **Use power tools only with specifically designated battery packs.** Use of any other battery packs may create a risk of injury and fire.

c. **When battery pack is not in use, keep it away from other metal objects, like paper clips, coins, keys, nails, screws or other small metal objects, that can make a connection from one terminal to another.** Shorting the battery terminals together may cause burns or a fire.

d. **Under abusive conditions, liquid may be ejected from the battery; avoid contact. If contact accidentally occurs, flush with water. If liquid contacts eyes, additionally seek medical help.** Liquid ejected from the battery may cause irritation or burns.

#### 6. Service

a. **Have your power tool serviced by a qualified repair person using only identical replacement parts.** This will make sure that the safety of the power tool is maintained.

#### Additional power tool safety warnings



**Warning!** Additional safety warnings for chainsaws.

◆ **Hold power tool by insulated gripping surfaces when performing an operation where the cutting tool may contact hidden wiring or its own cord.**

Contact with a "live" wire will also make exposed metal parts of the power tool "live" and give the operator an electric shock.

- ◆ **Keep all parts of the body away from the saw chain when the chainsaw is operating. Before you start the chainsaw, make sure the saw chain is not contacting anything.** A moment of inattention while operating the chainsaw may cause entanglement of your clothing or body with the chainsaw.
- ◆ **Always hold the chainsaw with your right hand on the rear handle and your left hand on the front handle.** Holding the chainsaw with the reversed hand configuration increases the risk of personal injury and should never be done.
- ◆ **Wear safety glasses and hearing protection. Further protective equipment for head, hands, legs and feet is recommended.** Adequate protective clothing will reduce personal injury by flying debris or accidental contact with the saw chain.
- ◆ **Do not operate a chainsaw in a tree.** Operation of a chainsaw while up in a tree may result in personal injury.
- ◆ **Always keep proper footing and operate the chainsaw only when standing on fixed, secure and level surface.** Slippery or unstable surfaces such as ladders may cause a loss of balance or control of the chainsaw.
- ◆ **When cutting a limb that is under tension be alert for spring back.** When the tension in the wood fibres is released the spring loaded limb may strike the operator and/or throw the chainsaw out of control.
- ◆ **Use extreme caution when cutting brush and saplings.** The slender material may catch the saw chain and be whipped toward you or pull you off balance.
- ◆ **Carry the chainsaw by the front handle with the chainsaw switched off and away from your body. When transporting or storing the chainsaw always fit the guide bar cover.** Proper handling of the chainsaw will reduce the likelihood of accidental contact with the moving saw chain.
- ◆ **Follow instructions for lubricating, chain tensioning and changing accessories.** Improperly tensioned or lubricated chain may either break or increase the chance for kickback.
- ◆ **Keep handles dry, clean, and free from oil and grease.** Greasy, oily handles are slippery causing loss of control.
- ◆ **Cut wood only. Do not use chainsaw for purposes not intended. For example: do not use the chainsaw for cutting plastic, masonry or non-wood building**

**materials.** Use of the chainsaw for operations different than intended could result in a hazardous situation.

- ◆ **Position the cord so that it will not get caught on branches or similar when cutting.**
- ◆ **The spiked bumper may become sharp during the life of the product. Handle with care.**
- ◆ **When handling the product the chain bar may become hot, handle with care.**

#### Additional power tool safety warnings



**Warning!** Additional safety warnings for compact chainsaws.

The intended use is described in this instruction manual. Do not use the tool for purposes not intended; for example do not use the tool to fell trees. The use of any accessory or attachment or performance of any operation with this tool other than those recommended in this instruction manual may present a risk of personal injury.

- ◆ Wear close fitting and protective clothing including a safety helmet with visor/goggles, ear protectors, non-skid safety footwear, protective bib trousers and strong leather gloves.
- ◆ Always position yourself out of the path of falling branches.
- ◆ The safe distance between a branch to be felled and bystanders, buildings and other objects is at least 2 1/2 times the length of the branch. Any bystander, building or object within this distance is at risk from being struck by the falling branch.
- ◆ Pre-plan a safe exit from falling branches. Ensure the exit route is clear of obstacles that would prevent or hinder movement. Remember wet grass and freshly cut bark is slippery.
- ◆ Ensure someone is nearby (but at a safe distance) in case of an accident.
- ◆ Do not use the tool while standing in a tree, on a ladder or on any other unstable surface.
- ◆ Keep proper footing and balance at all times.
- ◆ Hold the tool firmly with both hands when the motor is running.
- ◆ Do not let the moving chain contact any object at the tip of the guide bar.
- ◆ Start cutting only with the chain moving at full speed.
- ◆ Do not attempt to enter a previous cut. Always make a fresh cut.
- ◆ Watch for shifting branches or other forces that could close a cut and pinch or fall into the chain.
- ◆ Do not attempt to cut a branch when the diameter of the branch exceeds the cutting length of the tool.

- ◆ Always remove the battery from the tool and place the chain cover assembly over the chain when storing or transporting the tool.
- ◆ Keep the saw chain sharp and properly tensioned. Check the tension at regular intervals.
- ◆ Switch the tool off, allow the chain to stop and remove the battery from the tool before carrying out any adjustment, servicing or maintenance.
- ◆ Only use genuine replacement parts and accessories.

#### Causes and operator prevention of kickback

Kickback may occur when the nose or tip of the guide bar touches an object, or when the wood closes in and pinches the saw chain in the cut.

Tip contact in some cases may cause a sudden reverse reaction, kicking the guide bar up and back towards the operator.

Pinching the saw chain along the top of the guide bar may push the guide bar rapidly back towards the operator.

Either of these reactions may cause you to lose control of the chainsaw which could result in serious personal injury. Do not rely exclusively upon the safety devices built into your chainsaw. As a chainsaw user, you should take several steps to keep your cutting jobs free from accident or injury.

Kickback is the result of tool misuse and / or incorrect operating procedures or conditions and can be avoided by taking proper precautions as given below:

- ◆ **Maintain a firm grip, with thumbs and fingers encircling the chainsaw handles. With both hands on the chainsaw, position your body and arm to allow you to resist kickback forces.** Kickback forces can be controlled by the operator, if proper precautions are taken. Do not let go of the chainsaw.
- ◆ **Do not overreach and do not cut above shoulder height.** This helps prevent unintended tip contact and enables better control of the chainsaw in unexpected situations.
- ◆ **Only use replacement guide bars and chains specified by the manufacturer.** Incorrect replacement guide bars and chains may cause chain breakage and/or kickback.
- ◆ **Follow the manufacturer's sharpening and maintenance instructions for the saw chain.** Decreasing the depth gauge height can lead to increased kickback.

#### Safety recommendations for the chainsaw

- ◆ We strongly recommend that first time users obtain practical instruction in the use of the chainsaw and protective equipment from an experienced user. Initial practice should be completed sawing logs on a saw horse or cradle.
- ◆ We recommend that when carrying the chainsaw that you make sure that the brake is engaged

- ◆ Maintain your chainsaw when not in use. Do not store your chainsaw for any length of time without first removing the saw chain and guide bar which should be kept immersed in oil. Store all parts of your chainsaw in a dry, secure place out of reach of children.
- ◆ We recommend you drain the oil reservoir prior to storage.
- ◆ Be sure of your footing and pre-plan a safe exit from a falling tree or branches.
- ◆ Use wedges to help control felling and prevent binding the guide bar and saw chain in the cut.
- ◆ Saw chain care. Keep the saw chain sharp and snug on the guide bar. Ensure the saw chain and guide bar are clean and well oiled. Keep handles dry, clean and free from oil and grease.

Kickback can be caused by:

- ◆ Striking branches or other objects accidentally with a tip of the saw while the saw chain is moving.
- ◆ Striking metal, cement or any other hard material near the wood, or buried in the wood.
- ◆ A dull or loose chain.
- ◆ Cutting above shoulder height.
- ◆ Lack of attention when holding or guiding the chainsaw while cutting.
- ◆ Over-reaching. Keep proper footing and balance at all times and do not overreach.
- ◆ Do not try to insert into a previous cut. As this could cause kickback. Make a fresh cut every time.
- ◆ We strongly recommend you do not attempt to operate your chainsaw while in a tree, on a ladder or on any other unstable surface. If you decide to do so, be advised that these positions are extremely dangerous.
- ◆ When cutting a branch that is under tension, be alert for spring back so that you will not be struck when the tension is released.

Avoid cutting:

- ◆ Prepared timber.
- ◆ Into the ground.
- ◆ Into wire fences, nails, etc.
- ◆ Into small sized brush and saplings because slender material may catch the saw chain and be whipped towards you, or pull you off balance.
- ◆ Do not use your chainsaw above shoulder height.
- ◆ Ensure someone is nearby (but at a safe distance) in case of an accident.
- ◆ If for any reason you have to touch the saw chain, make sure your chainsaw is disconnected from the mains.
- ◆ The noise from this product can exceed 80 dB(A). We therefore recommend you take appropriate measures for the protection of hearing.

## Safety of others

- ◆ This appliance is not intended for use by persons (including children) with reduced physical, sensory or mental capabilities, or lack of experience and knowledge, unless they have been given supervision or instruction concerning the use of the appliance by a person responsible for their safety.
- ◆ Children should be supervised to ensure that they do not play with the appliance.

## Vibration

The declared vibration emission values stated in the technical data and the declaration of conformity have been measured in accordance with a standard test method provided by EN 60745 and may be used for comparing one tool with another. The declared vibration emission value may also be used in a preliminary assessment of exposure.

**Warning!** The vibration emission value during actual use of the power tool can differ from the declared value depending on the ways in which the tool is used. The vibration level may increase above the level stated.

- ◆ When assessing vibration exposure to determine safety measures required by 2002/44/EC to protect persons regularly using power tools in employment, an estimation of vibration exposure should consider, the actual conditions of use and the way the tool is used, including taking account of all parts of the operating cycle such as the times when the tool is switched off and when it is running idle in addition to the trigger time.

## Warning symbols

The following warning symbols are found on your tool:



**Warning!** To reduce the risk of injury, the user must read the instruction manual.



Do not use your saw in wet conditions or expose it to rain.



Always wear head and eye protection.



Always wear ear protection.



Always wear eye protection.



Always wear non-slip safety footwear.





Beware of falling objects.

Keep bystanders away.



To ensure continued safe operation, check the chain tension as described in this manual after every 10 minutes of use, and adjust back to a clearance of 3 mm as required. Oil the chain after every 10 minutes of use.



**Warning!** Do not touch chain at the chip ejection point.



Direction of rotation of the chain.



To ensure continued safe operation, the chain and guide bar must only be replaced with original Black & Decker parts. Replacement chain part number A6158 replacement guide bar part number 90517720.

## Additional safety instructions for batteries and chargers

### Batteries

- ◆ Never attempt to open for any reason.
- ◆ Do not expose the battery to water.
- ◆ Do not expose the battery to heat.
- ◆ Do not store in locations where the temperature may exceed 40°C.
- ◆ Charge only at ambient temperatures between 10°C and 40°C.
- ◆ Charge only using the charger provided with the appliance/tool. Using the wrong charger could result in an electric shock or overheating of the battery.
- ◆ When disposing of batteries, follow the instructions given in the section "Protecting the environment".
- ◆ Do not damage/deform the battery pack either by puncture or impact, as this may create a risk of injury and fire.
- ◆ Do not charge damaged batteries.

**Under extreme conditions, battery leakage may occur.**

**When you notice liquid on the batteries, carefully wipe the liquid off using a cloth. Avoid skin contact.**

**In case of skin or eye contact, follow the instructions below.**

**Warning! The battery fluid may cause personal injury or damage to property. In case of skin contact, immediately rinse with water. If redness, pain or irritation occurs seek medical attention. In case of eye contact, rinse immediately with clean water and seek medical attention.**

### Chargers

**Warning! Your charger has been designed for a specific voltage. Always check that the mains voltage corresponds to the voltage on the rating plate.**

**Warning! Never attempt to replace the charger unit with a regular mains plug.**

- ◆ Use your Black & Decker charger only to charge the battery in the appliance/tool with which it was supplied. Other batteries could burst, causing personal injury and damage.
- ◆ Never attempt to charge non-rechargeable batteries.
- ◆ If the supply cord is damaged, it must be replaced by the manufacturer or an authorised Black & Decker Service Centre in order to avoid a hazard.
- ◆ Do not expose the charger to water.
- ◆ Do not open the charger.
- ◆ Do not probe the charger.
- ◆ The charger must be placed in a well ventilated area when charging.

### Labels on the charger

The following symbols are found on your charger:



Your charger is double insulated; therefore no earth wire is required. Always check that the power supply corresponds to the voltage on the rating plate. Never attempt to replace the charger unit with a regular mains plug.

If the supply cord is damaged, it must be replaced by the manufacturer or an authorised Black & Decker Service Centre in order to avoid a hazard.



The charging base is intended for indoor use only.



Read the instruction manual before use.

### Features

1. On/off switch
2. Lock-off button
3. Oil cap
4. Oil reservoir
5. Front guard assembly
6. Chain cover assembly
7. Chain tension adjustment screw
8. Chain
9. Guide bar
10. Battery
11. Chain sheath
12. Charger

## Assembly

**Warning!** Before assembly, remove the battery (10) from the tool.

### Fitting and removing the battery (fig. A)

- ◆ To fit the battery (10), line it up with the receptacle on the tool. Slide the battery (10) into the receptacle and push until the battery (10) snaps into place.
- ◆ To remove the battery (10), push the release button (24) while at the same time pulling the battery (10) out of the receptacle.

**Warning!** To prevent accidental operation, make sure that the battery is removed and that the chain sheath (11) is in place on the saw chain (8) before performing the following operations. Failure to do this could result in serious personal injury.

### Charging the battery (fig. B)

The battery needs to be charged before first use and whenever it fails to produce sufficient power on jobs that were easily done before. The battery may become warm while charging; this is normal and does not indicate a problem.

**Warning!** Do not charge the battery at ambient temperatures below 10 °C or above 40 °C. Recommended charging temperature: approx. 24 °C.

**Note:** The charger will not charge a battery if the cell temperature is below approximately 10 °C or above 40 °C. The battery should be left in the charger and the charger will begin to charge automatically when the cell temperature warms up or cools down.

- ◆ To charge the battery (10), insert it into the charger (12).  
The battery will only fit into the charger in one way. Do not force. Be sure that the battery is fully seated in the charger.
- ◆ Plug in the charger and switch on at the mains.

The charging indicator (23) will blink.

The charge is complete when the charging indicator (23) switches to continuously on. The charger and the battery can be left connected indefinitely. The LED will switch on as the charger occasionally tops up the battery charge.

- ◆ Charge discharged batteries within 1 week. Battery life will be greatly diminished if stored in a discharged state.

### Leaving the battery in the charger

The charger and battery pack can be left connected with the LED glowing indefinitely. The charger will keep the battery pack fresh and fully charged.

## Installing and removing the saw chain (fig. C, E & G)



Always wear protective gloves when installing or removing the saw chain (8). The saw chain is sharp and can cut you when it is not running.

- ◆ Place the tool on a firm and stable surface.
- ◆ Loosen the two Allen screws (14) using the Allen key (21) provided. Remove the Allen screws (14).
- ◆ Remove the chain cover assembly (6).
- ◆ Turn the chain tension adjustment screw (7) counter clockwise to allow the guide bar (9) to recede and to reduce the tension on the saw chain (8).
- ◆ Remove the old saw chain (8) from the sprocket (15) and the guide bar (9).
- ◆ Place the new saw chain (8) in the groove of the guide bar (9) and around the sprocket (15). Make sure that the teeth are facing the correct direction by matching the arrow on the saw chain (8) with the arrow on the chain cover assembly (6).
- ◆ Make sure that the slot (17) in the guide bar (9) is over the location pins (18) and that the hole (20) below the slot is located over the adjustment pin (19).
- ◆ Fit the chain cover assembly (6) and the 2 Allen screws (14).
- ◆ Tighten the Allen screws (14) using the Allen key (21) provided.
- ◆ Adjust the chain tension as described below.

## Checking and adjusting the chain tension (fig. C and E)

- ◆ Check the saw chain tension. The tension is correct when the saw chain (8) snaps back after being pulled away 3 mm from the guide bar (9) with light force from the middle finger and thumb. There should be no 'sag' between the guide bar (9) and the saw chain (8) on the underside.

### To adjust the tension:

- ◆ Loosen the 2 Allen screws (14).
- ◆ Turn the chain tension adjustment screw (7) clockwise.

**Warning!** Do not over-tension the chain as this will lead to excessive wear and will reduce the life of the bar and chain.

- ◆ Once the chain tension is correct, tighten the 2 Allen screws (14).

**Warning!** When the saw chain is new, check the tension frequently during the first two hours of use as a new saw chain stretches slightly.

## Filling the oil reservoir (fig. G)

- ◆ Remove the oil cap (3) and fill the reservoir (4) with the recommended chain oil. You can see the oil level in the oil reservoir (4). Refit the oil cap (3).
- ◆ Periodically switch off and check the oil level; if it is less than a quarter full, remove the battery (10) from the tool and refill the reservoir (4) with the correct oil.

## Oiling the chain (fig. G)

The saw chain (8) must be oiled before each use and after cleaning using only the correct grade of oil (cat. no. A6027).

- ◆ Lubricate the saw chain (8) by pressing the bulb on the oil cap (3) twice before making each cut, holding the bulb down for 3-4 seconds.

## Residual risks

Additional residual risks may arise when using the tool which may not be included in the enclosed safety warnings. These risks can arise from misuse, prolonged use etc.

Even with the application of the relevant safety regulations and the implementation of safety devices, certain residual risks cannot be avoided. These include:

- ◆ Injuries caused by touching any rotating/moving parts.
- ◆ Injuries caused when changing any parts, blades or accessories.
- ◆ Injuries caused by prolonged use of a tool. When using any tool for prolonged periods make sure you take regular breaks.
- ◆ Impairment of hearing.
- ◆ Health hazards caused by breathing dust developed when using your tool (example:- working with wood, especially oak, beech and MDF).

## Use

Switching on and off (fig. G)

**Warning!** Let the tool work at its own pace, Do not overload.

For your safety, this tool is equipped with a double switching system. This system prevents starting the tool inadvertently.

### Switching on

- ◆ Press the lock-off button (2) and at the same time squeeze the on/off switch (1).
- ◆ Release the lock-off button (2).

### Switching off

- ◆ Release the on/off switch (1).

**Warning!** Never attempt to lock a switch in the on position.

## Pruning trees (fig. H)

Make sure that there are no local by-laws or regulations that would prohibit or control the pruning of the tree limbs.

Pruning should only be undertaken by experienced users there is an increased risk of the saw chain (8) pinching and kickback.

Before pruning consideration should be given to conditions affecting the direction of fall including:

- ◆ The length and weight of the branch to be cut.
- ◆ Any unusual heavy limb structure or decay.
- ◆ Surrounding trees and obstacles including overhead.
- ◆ The wind speed and direction.
- ◆ The branch being intertwined with other branches.

The operator should consider access to the tree limb and the direction of fall. The tree branch is liable to swing towards the tree trunk. In addition to the user bystanders, objects and property below the branch will be at risk.

To avoid splintering, the first cut is made in an upward direction to a maximum depth of one third the diameter of the branch. The second cut is made downwards to meet the first.

## Light duty cutting (fig. I)

How you should cut depends on how the log is supported. Use a saw horse whenever possible. Always start a cut with the saw chain (8) running and the spiked bumper in contact with the wood. To complete the cut, use a pivoting action of the spiked bumper against the wood.

When supported along its whole length:

- ◆ Make a downward cut, but avoid cutting the earth as this will blunt your saw chain quickly.

When supported at both ends:

- ◆ First, cut one third down to avoid splintering and second, cut again to meet the first cut,

When supported at one end:

- ◆ First cut one third up to avoid splintering and second, cut down to prevent splintering.

When on a slope:

- ◆ Always stand on the uphill side.

When using a saw horse (fig. 1):

This is strongly recommended whenever possible.

- ◆ Position the log in a stable position. Always cut on the outside of the saw horse arms. Use clamps or straps to secure the workpiece.

## Cleaning, maintenance and storage

Your Black & Decker tool has been designed to operate over a long period of time with a minimum of maintenance.

Continuous satisfactory operation depends upon proper tool care and regular cleaning.

Your charger does not require any maintenance apart from regular cleaning.

**Warning!** Before performing any maintenance on the tool, remove the battery from the tool. Unplug the charger before cleaning it.

### After use and before storage

Regularly clean the ventilation slots with a clean, dry paint brush.

To clean the tool, use only mild soap and a damp cloth. Never let any liquid get inside the tool and never immerse any part of the tool into liquid.

- ◆ Remove debris using a hard brush.
- ◆ Lubricate the chain (8) with oil.

### Saw chain sharpening

If you are to get the best possible performance from the tool it is important to keep the teeth of the saw chain sharp.

Guidance for this procedure is found on the sharpener package. For this purpose we recommend the purchase of the Black & Decker saw chain sharpening kit, available from your Black & Decker service agents (cat. no. A6039).

### Replacing worn out or damaged saw chains and guide bars

Replacement saw chains are available through retailers and Black & Decker service agents (pt no A6158), replacement guide bars are only available through Black & Decker service agents (pt no 90517720). To avoid the risk of injury, use only original Black & Decker chains and guide bars. Always use genuine spare parts.

### Saw chain sharpness

The saw chain cutters will blunt immediately if they touch the ground or a nail whilst cutting.

## Saw chain tension

Regularly check the saw chain tension.

### What to do if your chainsaw needs repair.

Your tool is in accordance with the relevant safety requirements. Repairs should only be carried out by a qualified person using original spare parts otherwise this may result in considerable danger to the user. We recommend you keep this user manual in a safe place.

## Storage

When the tool will not be used for several months, ideally leave the battery (10) connected to the charger.

Otherwise proceed as follows:

- ◆ Remove the battery (10) from the tool.
- ◆ Fully charge the battery (10).
- ◆ Store the tool and battery (10) in a secure and dry location. The storage temperature must always remain in the range of +10°C to +40°C. Place the battery (10) on a level surface.
- ◆ Before using the tool after prolonged storage, fully charge the battery (10) again.

## Protecting the environment



Separate collection. This product must not be disposed of with normal household waste.

Should you find one day that your Black & Decker product needs replacement, or if it is of no further use to you, do not dispose of it with household waste. Make this product available for separate collection.



Separate collection of used products and packaging allows materials to be recycled and used again. Re-use of recycled materials helps prevent environmental pollution and reduces the demand for raw materials.

Local regulations may provide for separate collection of electrical products from the household, at municipal waste sites or by the retailer when you purchase a new product.

Black & Decker provides a facility for the collection and recycling of Black & Decker products once they have reached the end of their working life. To take advantage of this service please return your product to any authorised repair agent who will collect them on our behalf.

You can check the location of your nearest authorised repair agent by contacting your local Black & Decker office at the address indicated in this manual. Alternatively, a list of authorised Black & Decker repair agents and full details of our after-sales service and contacts are available on the Internet at: [www.2helpU.com](http://www.2helpU.com).

### Batteries



At the end of their useful life, discard batteries with due care for our environment:

- ◆ Do not short-circuit the battery terminals.
- ◆ Do not dispose of the battery(s) in a fire as this may result in a risk of personal injury or an explosion.
- ◆ Run the battery down completely, then remove it from the tool.
- ◆ Batteries are recyclable. Place the battery(s) in a suitable packaging to ensure that the terminals cannot be short-circuited. Take them to any authorised repair agent or a local recycling station.

### Technical data

GKC1820L H1	
Voltage	Vdc 18
No load chain speed	min <sup>-1</sup> 190
Weight	kg 2

BL1518	
Voltage	Vdc 18
Capacity	Ah 1.5
Type	Li-Ion

905902** TYPE 1	
Input voltage	Vac 100-240
Output voltage	Vdc 8-20
Output current	mA 400

Guaranteed sound pressure level measured according to EN60745:

$L_{pA}$  (sound pressure) 78.6 dB(A), uncertainty (K) 3 dB(A)  
 $L_{WA}$  (sound power) 89.6 dB(A), uncertainty (K) 3 dB(A)

Vibration total values (triax vector sum) according to EN 60745:

Vibration emission value ( $a_{H}$ )= 0.62 m/s<sup>2</sup>,  
 uncertainty (K) = 1.5 m/s<sup>2</sup>

## EC declaration of conformity

MACHINERY DIRECTIVE  
 OUTDOOR NOISE DIRECTIVE



GKC1820L

Black & Decker declares that these products described under "technical data" are in compliance with: 2006/42/EC, EN60745-1, EN60745-2-13

2006/42/EC, Chain Saw, Annex IV  
 KEMA Quality B.V., Utrechtseweg 310, 6802 ED Arnhem, The Netherlands

Notified Body ID No.: 0344

Level of sound power according to 2000/14/EC (Article 13, Annex III):

$L_{WA}$  (measure sound power) 89.6 dB(A)

$L_{WA}$  (guaranteed sound power) 90 dB(A)

These products also comply with directive 2004/108/EC & 2011/65/EU. For more information, please contact Black & Decker at the following address or refer to the back of the manual.

The undersigned is responsible for compilation of the technical file and makes this declaration on behalf of Black & Decker.

Kevin Hewitt  
 Vice-President Global Engineering  
 Black & Decker Europe, 210 Bath Road, Slough,  
 Berkshire, SL1 3YD  
 United Kingdom  
 28-02-2013

## Guarantee

Black & Decker is confident of the quality of its products and offers an outstanding guarantee. This guarantee statement is in addition to and in no way prejudices your statutory rights. The guarantee is valid within the territories of the Member States of the European Union and the European Free Trade Area.

If a Black & Decker product becomes defective due to faulty materials, workmanship or lack of conformity, within 24 months from the date of purchase, Black & Decker guarantees to replace defective parts, repair products subjected to fair wear and tear or replace such products to ensure minimum inconvenience to the customer unless:

- ◆ The product has been used for trade, professional or hire purposes.
- ◆ The product has been subjected to misuse or neglect.
- ◆ The product has sustained damage through foreign objects, substances or accidents.
- ◆ Repairs have been attempted by persons other than authorised repair agents or Black & Decker service staff.

To claim on the guarantee, you will need to submit proof of purchase to the seller or an authorised repair agent. You can check the location of your nearest authorised repair agent by contacting your local Black & Decker office at the address indicated in this manual. Alternatively, a list of authorised Black & Decker repair agents and full details of our after-sales service and contacts are available on the Internet at: **[www.2helpU.com](http://www.2helpU.com)**

Please visit our website **[www.blackanddecker.co.uk](http://www.blackanddecker.co.uk)** to register your new Black & Decker product and to be kept up to date on new products and special offers. Further information on the Black & Decker brand and our range of products is available at **[www.blackanddecker.co.uk](http://www.blackanddecker.co.uk)**.

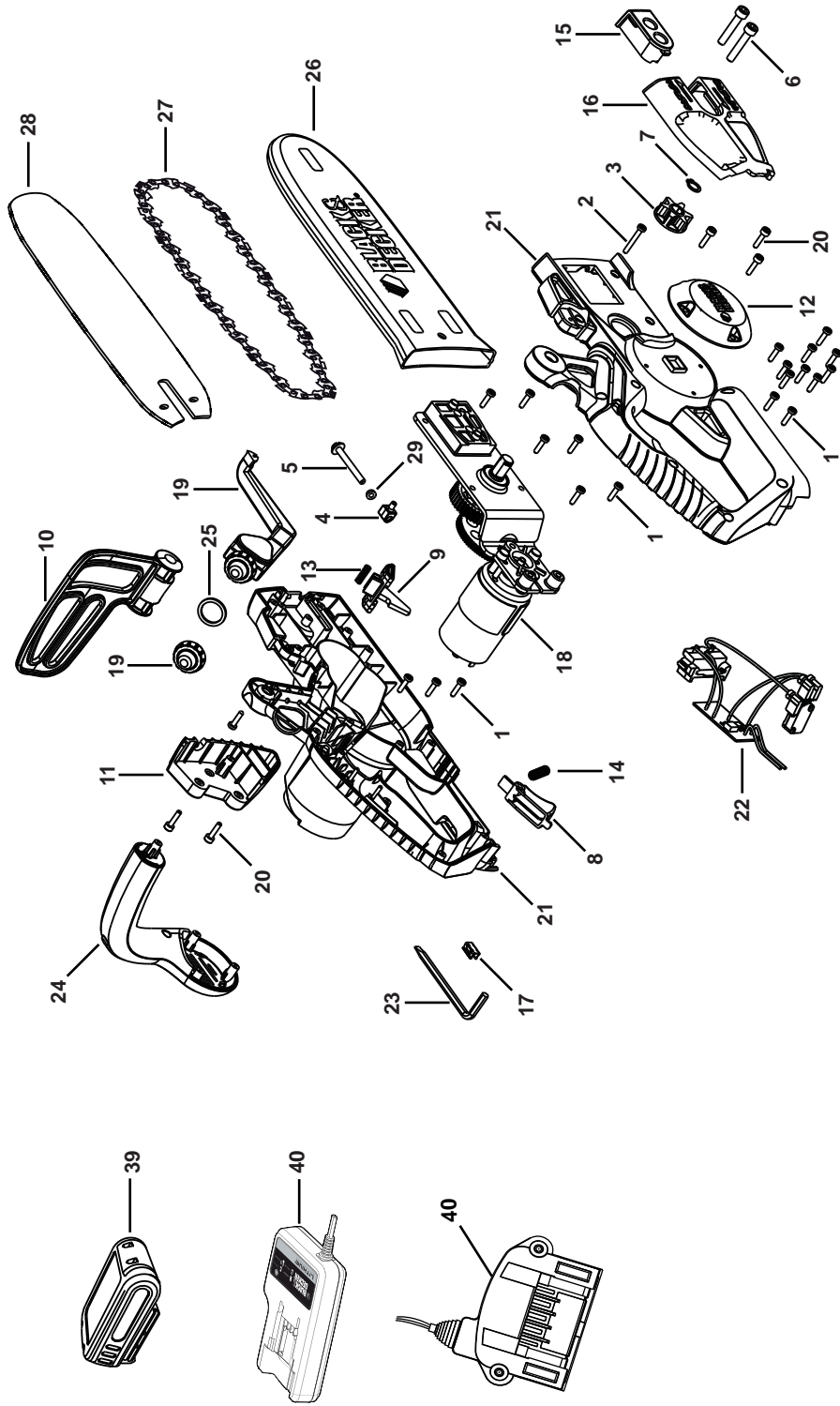

ENGLISH

**Do not forget to register your product!**  
**[www.blackanddecker.co.uk/productregistration](http://www.blackanddecker.co.uk/productregistration)**

Register your product online at [www.blackanddecker.co.uk/productregistration](http://www.blackanddecker.co.uk/productregistration) or send your name, surname and product code to Black & Decker in your country.

**Australia**

Black & Decker (Australia) Pty. Ltd.  
20 Fletcher Road, Mooroolbark,  
Victoria, 3138

Tel. 03-8720 5100  
Fax 03-9727 5940

**New Zealand**

Black & Decker  
5 Te Apunga Place  
Mt Wellington  
Auckland 1060

Tel. +64 9 259 1133  
Fax +64 9 259 1122

**United Kingdom**

Black & Decker  
210 Bath Road  
Slough, Berkshire SL1 3YD

Tel. 01753 511234  
Fax 01753 551155  
Helpline 01753 574277